

This drawing contains designs and other information which are property of LMI Corporation. This drawing may not, in whole or in part be duplicated or disclosed or used for manufacture of the part disclosed herein, without the prior written permission of LMI Corporation. LMI is dedicated to continuous product development and therefore reserves the right to modify the design without notice. Contact LMI to verify current design specifications.

Tracing Template

ACCESS HOLES FOR SECURING THE LMI776 (2 PLCS)

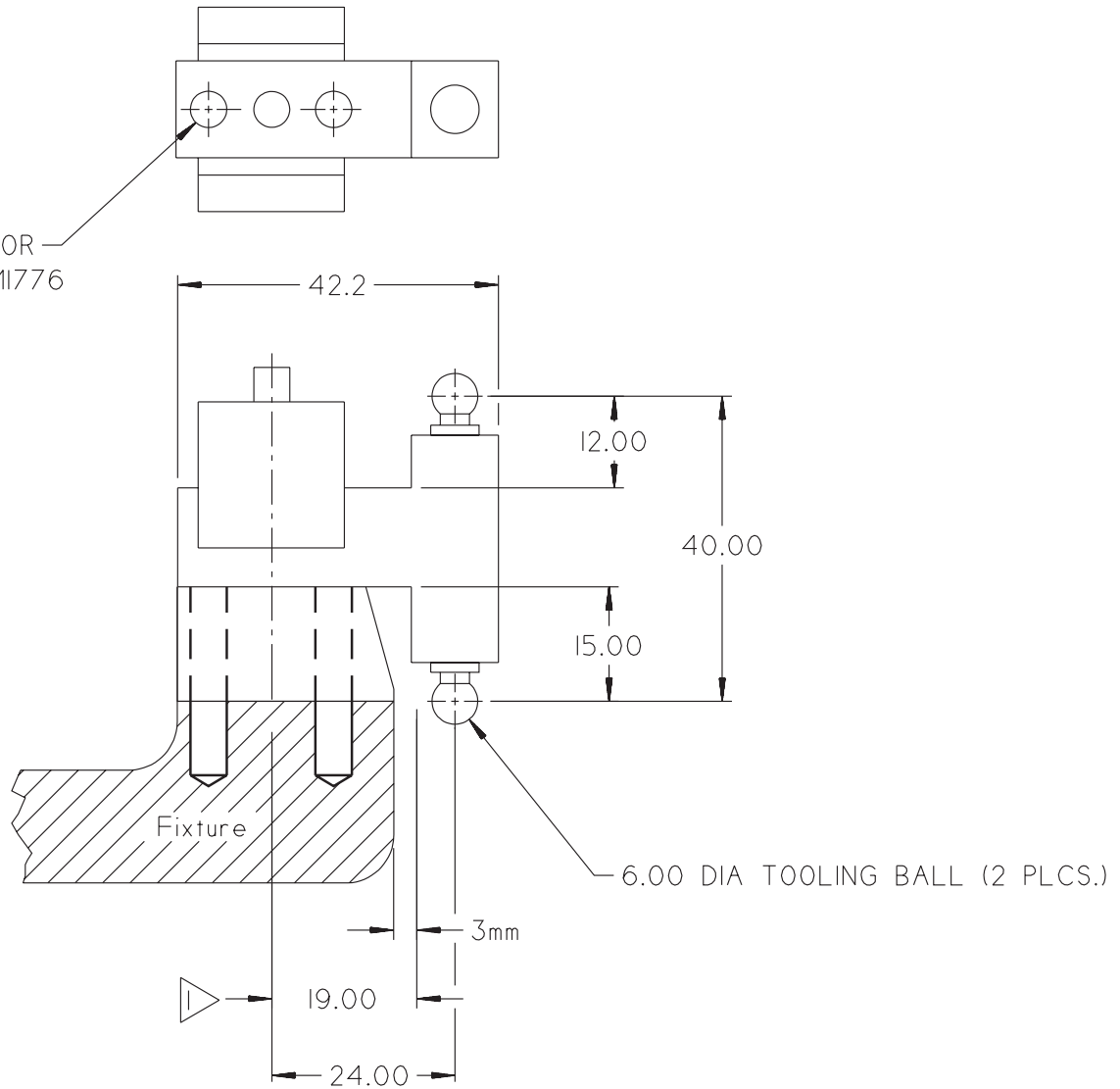

▷ SUBTRACT 5mm FROM 24mm "KNOWN DIMENSION" TO SET LMI776 BLOCK FOR 3mm GAP NOMINAL.

MANUFACTURED UNDER ONE OR MORE OF THE FOLLOWING PATENTS:
 #4345380: #4731935: #4787151: #4831742: #4831743: #4843727: #5787017



TITLE: LMI 049 TOOLING AID	
SHEET: 1 of 1	REV DATE: 10/21/98