

This drawing contains designs and other information which are property of LMI Corp. This drawing may not, in whole or in part, be duplicated or disclosed or used for manufacture of the part disclosed herein, without the prior written permission of LMI Corp. LMI is dedicated to continuous product development and therefore reserves the right to modify the design without notice

TRACING TEMPLATE

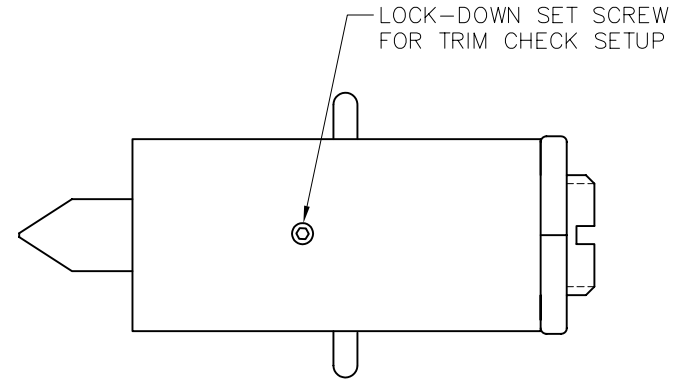

CUSTOM PIN LENGTHS AND GEOMETRY AVAILABLE

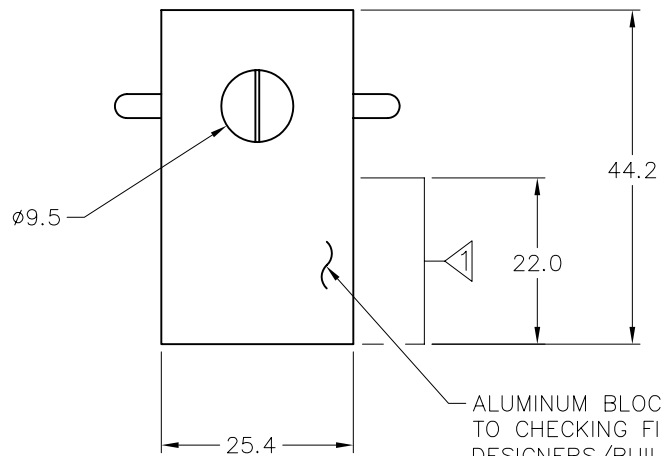
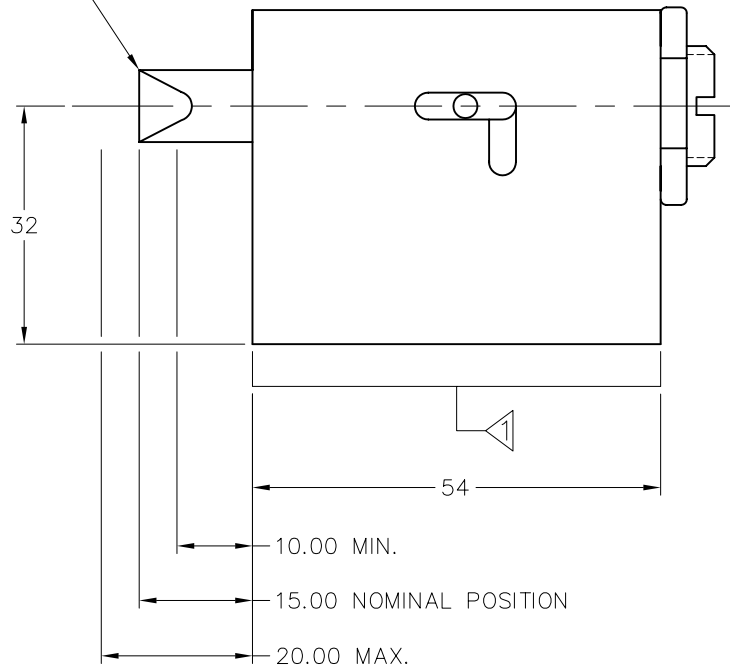

ALUMINUM BLOCK TO BE ATTACHED TO CHECKING FIXTURE AT DESIGNERS/BUILDERS DISCRETION.

BRACKET SHOWS ALLOWABLE AREA FOR BOLT HOLE PATTERN AND DOWELING.

LMI

PHONE #(810) 714-5811

TITLE: LMI268 TRIMCHECK "RAIL BLOCK"

SHEET: 1 OF 1

REV DATE: 05/15/06