

This drawing contains designs and other information which are property of LMI Corporation. This drawing may not, in whole or in part be duplicated or disclosed or used for manufacture of the part disclosed herein, without the prior written permission of LMI Corporation. LMI is dedicated to continuous product development and therefore reserves the right to modify the design without notice. Contact LMI to verify current design specifications.

CUSTOM CONFIGURATIONS AVAILABLE.

# Tracing Template

View A

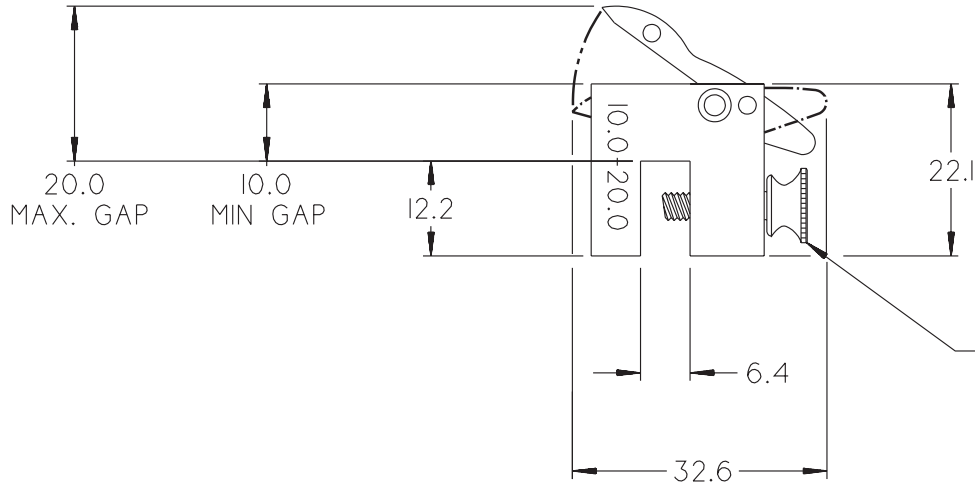

LOCKING THUMB SCREW

View B

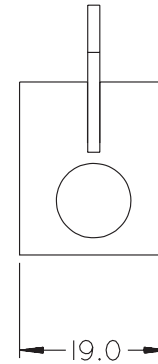

NOTE: SEE MODEL LMI236 ISOMETRIC DRAWING FOR VIEW REFERENCE.

- SHOWN IS A 10.0-20.0mm GAP CHECK BLOCK. OTHER GAP SIZES AVAILABLE.
- TO BE USED WITH THE LMI200-SB SERIES PROBES. AND THE LMI234 ADAPTOR.

**LMI**  
Corporation  
Phone # (810) 714-5811

TITLE: LMI236 DECK LID GAP GAGE

(10mm SPAN)

SHEET: 2 of 2

REV DATE: 08/12/97