

This drawing contains designs and other information which are property of LMI Corp. This drawing may not, in whole or in part, be duplicated or disclosed or used for manufacture of the part disclosed herein, without the prior written permission of LMI Corp. LMI is dedicated to continuous product development and therefore reserves the right to modify the design without notice

CUSTOM CONFIGURATIONS AVAILABLE.

# TRACING TEMPLATE

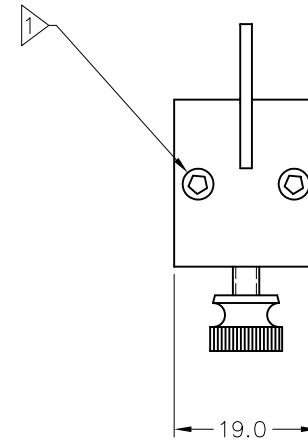
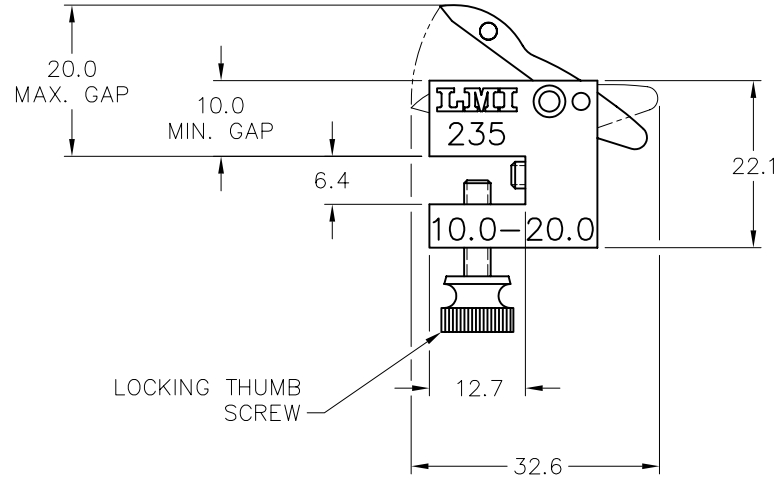

- NOTE: - SHOWN IS A 10.0-20.0mm GAP CHECK BLOCK, OTHER GAP SIZES AVAILABLE.  
 - TO BE USED WITH THE LMI200-SB SERIES PROBES AND THE LMI234 ADAPTER.

1 POSITIONING SCREW. USED TO ADJUST CONTACT POINT ON DOOR.

**LMI**  
 PHONE #(810) 714-5811

TITLE: LMI235 DOOR SEAL GAP GAGE	
(10mm SPAN)	
SHEET: 2 OF 2	REV DATE: 02/10/06